



To Whom it may concern,

We are Writing in relation to the Extraction system fit out at Shimla's, 293 Roundhay Rd, Harehills, Leeds LS8 4HS. The extraction fans were fitted with 1-meter Silencers on both sides of the Fans. The Fans were located on top of the roof therefore the Noise emitting from the fan should not have any disturbance to the surrounding properties. The ducting was all housed in false Brick wall on the outside of the building with insulation around it to dampen the noise completely. Air intake was positioned inside the kitchen therefore it does not let any noise to the neighbouring properties either.

All fixtures and fittings were mounted with Anti vibration mounts as well as rubber feet on the roof to eliminate any vibration coming from ducting or Fans.

Below are spec sheets of the Fans, silencers, and anti-vibration mounts etc.

For further information please do not hesitate to contact us.



Quotation Number	:	Project Code	:
Project Name	:	Customer	:
Item Reference:	:	Date:	: Friday, January 31, 2020

Fan Code 56 MaXfan Compac
 Fan Diameter / Size 560 Size / mm
 Fan Speed 2910 rpm
 Velocity 11.6 m/s
 Blade Angle 16°
 Installation Type / Form of Running D / AB (Vertical)
 Fan Casing Long

Requested Duty 2.81m³/s @ 474 Pa (static)
 Outlet Dynamic Pressure 81 Pa

Duty Shaft Power 2.09 kW
 Max Shaft Power 2.22 kW
 Total Efficiency 77.9 %

Motor Frame 90L [Class F]
 Motor Rating 2.64 kW [IE2]
 Full Load Current 9.36 A
 Starting Current 52.8 A
 Motor Mounting Pad
 Electrical Supply 220-240 Volts 50 Hz 1 Phase
 Start Type DOL
 Motor Winding Standard
 Enclosure Standard All

ErP [FMEG] Rating N 70 (ErP Compliant)
 ErP [FMEG] Target N 58
 FMEG Blade Angle [Range] 0° [0° - 0°]
 Measurement Category D (Total)
 VSD N
 Fan + Motor Efficiency 66.7% (3.44 m³/s @ 467 Pa)
 Motor Input Power (ErP) 2.41 kW

SFP value 0.88 W/(l/s) @ Requested Duty
 Power from mains 2.51 kW
 Energy Consumption 7529 kWh (3000 h/year)
 Running Cost / Year £678

Air Density 1.2 kg/m³ / 20 °C / 0 m / 50% RH
 Smoke Venting Non Smoke Venting
 Product Number EJ563236

Performance data has been derived from tests carried out in a Flakt Woods laboratory, in accordance with ISO 5801 and is specifically applicable for Ducted installations. When an electronic controller is incorporated, enhanced motor noise can occur - particularly when the operating speed is well below maximum. FWL therefore recommend using an auto transformer speed controller for noise sensitive applications. Bifurcateds are Erp exempt when used continuously at >100C. They are not for use in the EEA at lower temperatures.

The MaXfan Compac includes a preprogrammed inverter drive to operate via 1 phase supply, offering full speed control and optimised performance.

Acoustic data has been derived from tests carried out in a Flakt Woods laboratory, in accordance with BS 848 Pt 2, 1985 / BS EN ISO 5136 under Ducted conditions. The single figure provided is the overall Inlet sound pressure level at the specified distance, under spherical, free field conditions.

Acoustic figures for adjusted running speeds have been interpolated and are for reference only.

This Offer is made subject to the latest version of our A100-19 Terms and Conditions, a copy of which can be made available on request.

	Sound Spectrum (Hz)								Overall	
	63	125	250	500	1k	2k	4k	8k	Lw*	LpA @ 3 m**
Inlet*	85	92	89	91	88	85	79	77	97	73
Outlet*	86	94	90	91	89	86	80	78	98	73
Breakout*	76	73	64	66	64	59	61	54	79	49

* Lw dB re 10⁻¹² W
 ** dBA re 2x10⁻⁵ Pa
 Sound data at requested duty.

Description	Qty
Fan	
EJ563236 - 56 MaXfan Compac	1
Accessories	
Inverter	1
Thermistors	1



Quotation Number	:	Project Code	:
Project Name	:	Customer	:
Item Reference:	:	Date:	: Friday, January 31, 2020
		Fan Code	: 56 MaXfan Compac

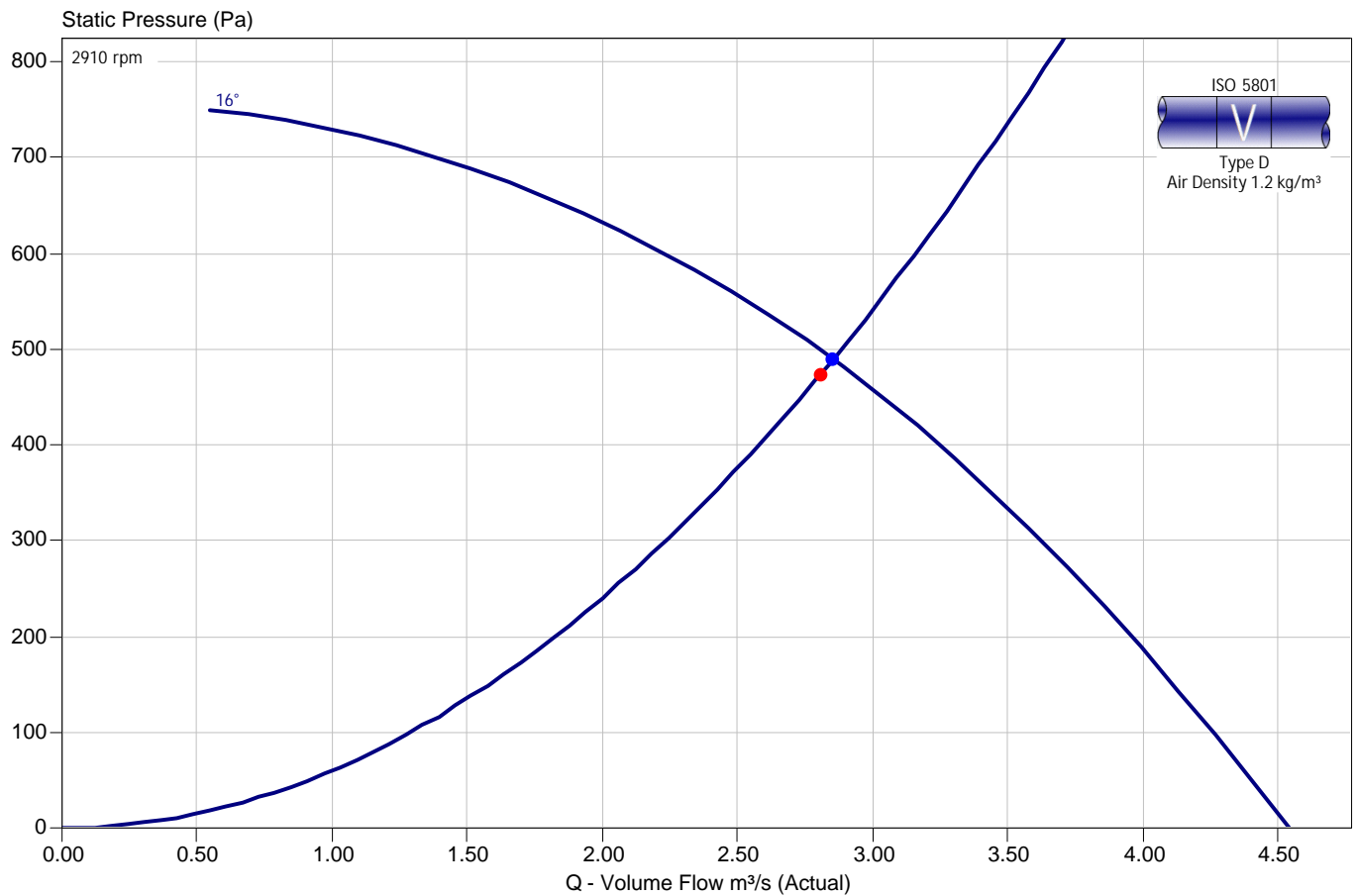
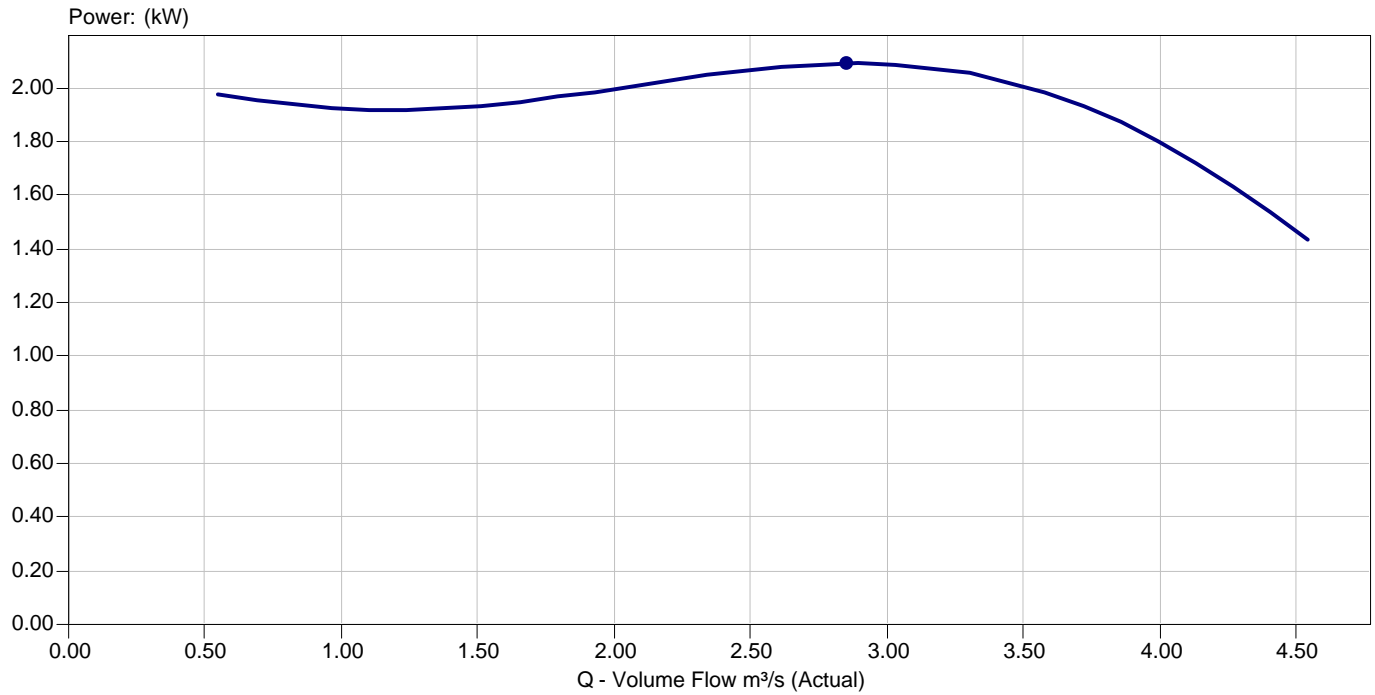



Quotation Number :
Project Name :
Item Reference :

Fan Code : 56 MaXfan Compac
Customer :
Date : Friday, January 31, 2020

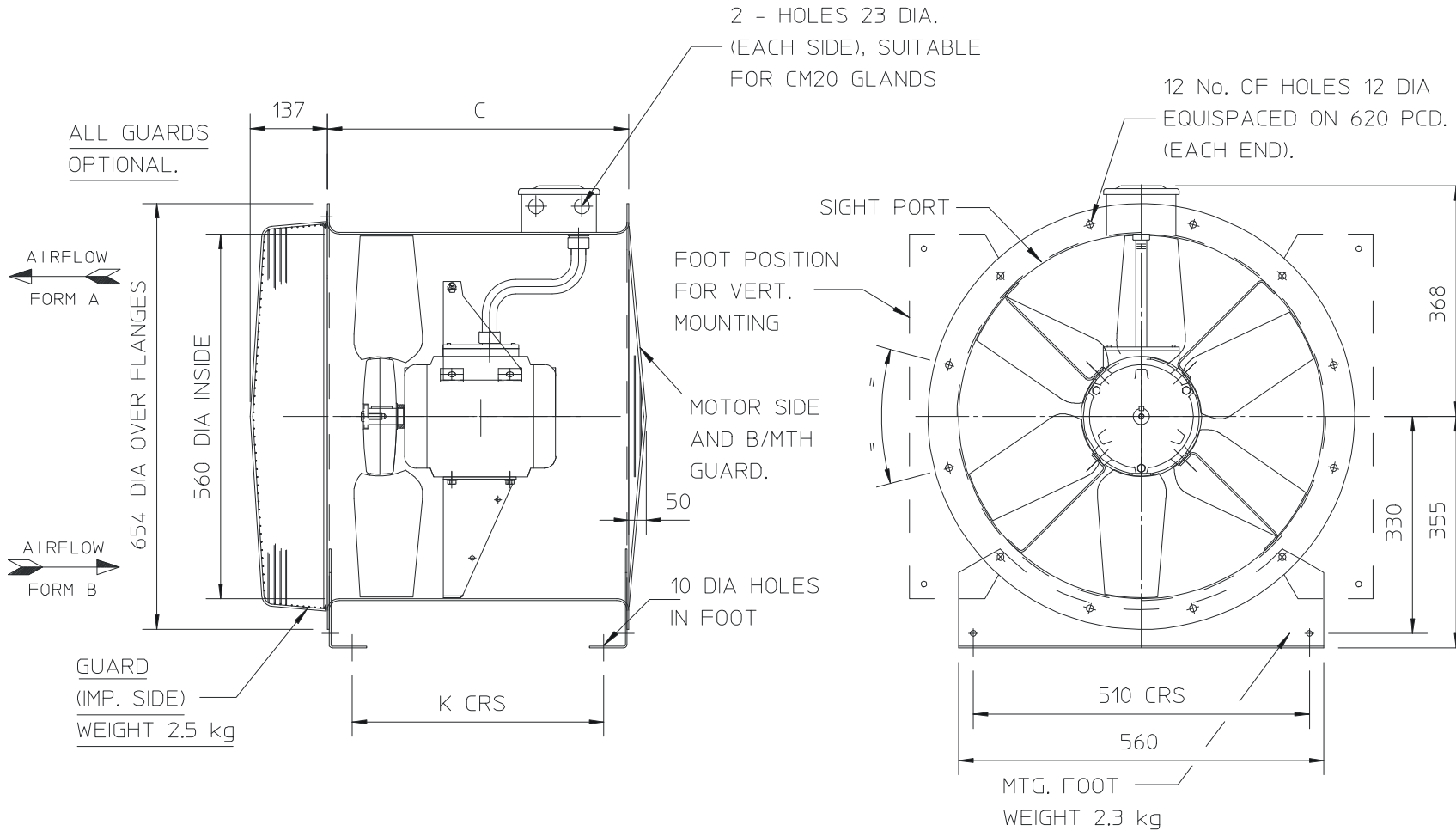

C	520
K	424
Weight (kg)	55

Notes : Dimensions shown in mm / Weight in kg

Reference: D275256

This drawing shows dimensions that should be used as a guide only and are subject to change. Certified drawings are available on request.

GigaBoxes are real multi-functional options that offer almost unlimited flexibility in various applications.

Compact frame construction and assembly-friendly accessories make a variable and thus optimal adaptation possible by simply repositioning the casing panels to the structural conditions. With five or (with series T120) three possible discharge directions this gives design flexibility to suit all site conditions. All types have integrated crane hooks for easier positioning as standard.

They are particularly suitable for medium to higher air flow volumes against high resistances in ventilation systems of every type. Furthermore, the new series GB.. T120 is suited for extraction of dirty, hot air up to 120° C. Altogether, 26 models are available with air flow volumes from 1400 to 19 000 m³/h for duct diameters 250 to 710 mm.

GigaBoxes from Helios are delivered complete with:

- Discharge adapter from square to circular ducted system for low-loss discharge

- Flexible sleeves to reduce vibration transmission and for the connection to ducts in the usual standard diameters.

Backward curved high output centrifugal impeller guarantees an energy-efficient operation at low noise emission.



Outdoor installation with wall bracket (accessories).



Roof installation with outdoor cover hood and external weather louvers (accessories).



Installation in the attic with anti vibration mounts (accessories).



GigaBox for air flow temperatures up to max. 120° C.



GB.. T120: The motor which is located outside of the air flow is separated from the impeller through a temperature insulated partition panel. The motor-impeller-unit is removable without disassembly of the ducting.



Assembly of the discharge adapter for GB.. T120 with centrifugal discharge direction to the top or to the side.



GB.. T120 with simply removable inspection cover.

The double-walled, removeable 20 mm thick side panels are noise and temperature insulated with flame-retardant mineral wool.

This allows for a variable installation and simple inspection access. Extensive accessories like wall bracket, condensate collector incl. condensate spigot (for GB.. T120 included in delivery), external weather louvers to cover the exhaust opening, outdoor cover hood for protected outdoor installation ensure for the necessary flexibility on site.

The T120 model impresses with outstanding benefits:

- Air flow temperature up to max. 120° C.
- Motor located outside of air flow.
- Temperature insulated partition panel between motor and impeller, lined with 20 mm thick, flame-retardant mineral wool.
- Easily accessible motor-impeller-unit, removable without disassembling the system components.
- Inspection cover with handle, simply remove for cleaning and maintenance.

- Condensate collector with condensate spigot included in delivery.
- Accessory components suitable for use to max. 120° C.

For applications with high air flow temperatures and/or steam/humidity present in the exhaust air, the GigaBox T120 is ideally suitable.

Ideal for application in exhaust air systems of process technology or in commercial kitchens.



The powerful and adaptable GigaBox from Helios.

GigaBox and accessory

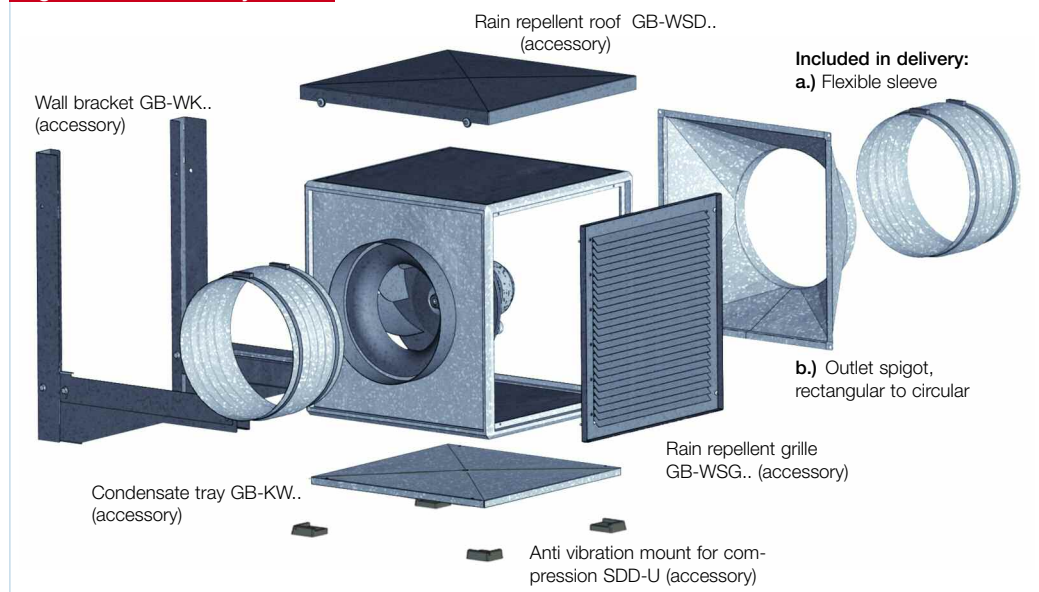

■ Application

Multifunctional fan box, suitable for medium to higher air flow volumes against high resistances in every type of ventilation system. The compact frame construction offers easy conversion of the outlet position. Together with a choice of ideal accessories make these units ideal for all applications.

The GB.. T120 types are suitable for the extraction of dirty, humid and hot air up to max. 120° C, i.e. as extract air fan in commercial kitchens and many applications of process technology.

■ Casing

Self-supporting frame construction from aluminium hollow profiles. Double-walled side panels from galvanised sheet steel, lined with 20 mm thick temperature insulating and flame-retardant mineral wool.

Intake cone for ideal airflow, spigot and flexible connector for duct connection. With outlet adapter (from square to circular) on the exhaust side for low-loss discharge and flexible connector to reduce vibration transmission. The flexible connectors are supplied as standard and correspond to the max. permissible air flow temperature of +70 °C and/or +120 °C with the types GB.. T120. Lifting lugs are standard for using crane hooks.

With GB.. T120 the motor is located outside of the air flow. The thermally insulated partition panel is also the support plate for the motor and impeller unit and can be removed completely for inspection without removing the complete fan from the system.

■ Speed control

All types (except GBD 630/4 T120) are speed controllable by voltage reduction using a 5-step transformer controller or an electronic controller. The 3-phase models can also be 2 speed controlled by star/delta switch (accessories DS 2 or full motor protection unit M 4). The performances of the speeds are given in the performance curve. 3-phase models are controllable with frequency inverters by installation of a sinusoidal filter (accessories) between inverter and motor. Type GBD 630/4 is only controllable by frequency inverter.

■ Assembly

□ Assembly of types GB..

Adaptable installation position and flexible assembly using the five possible discharge directions via the discharge adapter. Removable panels allow inspection access on all sides.

□ Assembly of types GB.. T120

Installation must be carried out with condensation discharge showing downward. Flexible assembly by three possible centrifugal discharge directions via the discharge adapter. Inspection cover with handle, for cleaning and maintenance simply remove. Lifting lugs are standard for using crane hooks. Vibration transmission to the building is minimised by anti vibration mounts (type SDD-U, accessories). Vibration transmission to the ducting is prevented by using the standard flexible connector supplied.

■ Impeller

Smooth running centrifugal impeller with backward curved polymer blades (size 250 from steel) on a galvanised steel back plate, direct driven. Size 500 and all GB.. T120 types with impellers from aluminium. These energy efficient impellers are low noise. Dynamically balanced assembled with the motor to DIN ISO 1940 Pt.1 – class 6.3 or 2.5.

■ Motor

IEC-standard motor or maintenance-free external rotor motor protected to IP 54 or 44. Thermal overload protection through built-in thermal contacts. Suitable for continuous operation S1. Insulation class F. Ball bearings are lubricated for life.

■ Electrical connection

Terminal box protection to IP 54.

■ Air flow direction

The air flow direction of centrifugal fans is not reversible, but can be set by positioning the fan to the required air flow direction. Furthermore the position can be set individually to constructional conditions through conversion of discharge adapter and panels. The correct motor rotation direction is marked through rotation arrows on the motor and has to be checked at start-up.

■ Incorrect direction of rotation

If the fan is operated in the incorrect direction of rotation the motor will overheat and the thermal contact will trip. Typical indication for this is a very low air flow combined with high noise levels and vibration.

■ Ambient temperature

The maximum permitted air flow temperature is given in the individual fan chart.

■ Surrounding temperature

From – 40° C to + 40° C.

Information	Pages
Design of systems, acoustic	12 on
General techn. information, speed control	17 on

Type GB..	Sound press. Case breakout	Sound press. Intake	Air flow volume \dot{V} m ³ /s against static pressure												
	L _{PA} dB(A)	L _{PA} dB(A)	$(\Delta P_{stat.})$ in Pa												
	at 4 m	at 4 m	0	50	100	150	200	250	300	350	400	500	600	700	800
GBW 250/4	27	39	0.389	0.319	0.244	0.147									
GBW 315/4	29	41	0.414	0.361	0.300	0.236	0.153	0.042							
GBW 355/4	34	46	0.817	0.747	0.675	0.594	0.505	0.400	0.258						
GBD 355/4/4	34	46	0.836	0.772	0.711	0.638	0.577	0.492	0.367	0.089					
GBW 400/4	38	50	1.142	1.092	1.036	0.975	0.917	0.85	0.764	0.656	0.511				
GBD 400/4/4	38	50	1.097	1.031	0.961	0.889	0.811	0.725	0.628	0.469	0.114				
GBW 450/4	40	52	1.514	1.433	1.361	1.292	1.217	1.122	1.006	0.867	0.692	0.083			
GBD 450/4/4	40	52	1.514	1.431	1.344	1.256	1.161	1.061	0.947	0.822	0.664	0.083			
GBW 500/4	45	57	2.333	2.236	2.139	2.042	1.947	1.85	1.744	1.628	1.506	1.219	0.778	0.042	
GBD 500/4/4	44	57	2.458	2.367	2.278	2.189	2.097	2.006	1.903	1.789	1.664	1.369	0.947	0.014	
GBW 500/6	35	46	1.600	1.478	1.347	1.189	0.978	0.678	0.144						
GBD 560/4/4	44	57	3.497	3.397	3.300	3.203	3.106	3.011	2.911	2.811	2.706	2.461	2.142	1.731	1.144
GBD 560/6/6	35	48	2.400	2.261	2.114	1.953	1.767	1.539	1.239	0.767					
GBD 630/4/4	48	61	4.153	4.058	3.961	3.869	3.775	3.683	3.592	3.500	3.403	3.194	2.953	2.675	2.333
GBD 630/6/6	43	56	3.192	2.992	2.794	2.597	2.375	2.103	1.767	1.356	0.792				
GBD 710/6/6	46	59	5.194	4.989	4.783	4.564	4.333	4.083	3.811	3.511	3.178	2.333	0.753		
Type GB.. T120	L _{PA} dB(A)	L _{PA} dB(A)	$(\Delta P_{stat.})$ in Pa												
	at 4 m	at 4 m	0	50	100	150	200	250	300	350	400	500	600	700	800
GBW 355/4 T120	36	49	0.961	0.894	0.831	0.767	0.683	0.567	0.418	0.201					
GBD 355/4/4 T120	36	49	0.964	0.908	0.846	0.778	0.697	0.594	0.469	0.192					
GBW 400/4 T120	40	53	1.369	1.293	1.217	1.136	1.053	0.942	0.806	0.622	0.439				
GBD 400/4/4 T120	40	53	1.353	1.275	1.193	1.106	1.014	0.900	0.761	0.581	0.381				
GBW 450/4 T120	45	57	1.975	1.887	1.800	1.700	1.625	1.525	1.426	1.317	1.208	0.917	0.528		
GBD 450/4/4 T120	45	57	1.994	1.914	1.833	1.750	1.653	1.556	1.450	1.336	1.206	0.897	0.372		
GBW 500/4 T120	45	59	2.318	2.244	2.158	2.075	1.989	1.903	1.800	1.696	1.575	1.300	0.975	0.511	
GBD 500/4/4 T120	45	59	2.319	2.239	2.157	2.081	1.994	1.911	1.833	1.739	1.642	1.381	1.061	0.533	
GBD 560/4/4 T120	48	62	3.417	3.322	3.247	3.164	3.078	2.994	2.910	2.817	2.722	2.533	2.336	2.064	1.671
GBD 630/4 T120	53	67	3.928	3.867	3.803	3.742	3.667	3.594	3.533	3.469	3.397	3.242	3.097	2.908	2.703

Special application for GigaBox T120 – commercial kitchens

For the design of exhaust air systems in commercial kitchens the VDI 2052 (2006) “Ventilation equipment for kitchens – design, layout, approval” is applied. This follows for extract air fan:

- Fans of exhaust air systems must be designed and installed in such a way that they are easily accessible, can be easily controlled and cleaned.
They must be able to be switched off from the kitchen.
The motors must be located outside of the extract air flow.
Connected kitchen extraction hoods must separate solid and liquid components, if possible.
A backdraft into following units is to be prevented.

These specific requirements from the GigaBoxes GB.. T120 are fulfilled in an outstanding manner. Easily accessible casing and double-walled side panels make cleaning simple with grease dissolving agents and steam possible.

Requirements in excess thereof of kitchen extract air units and the appropriate fire protection can deviate country-specifically; these special requirements of the respective country, in which the unit is to be used, must be considered.

NEW!

Models GB..

Arbitrary installation position and flexible assembly by five possible discharge directions.



Models GB.. T120

Designed for moving dirty, humid and hot air up to max. 120° C.

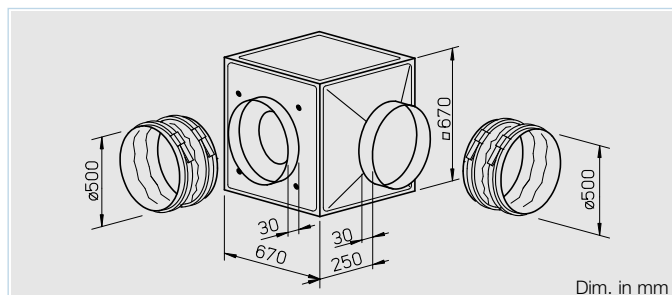
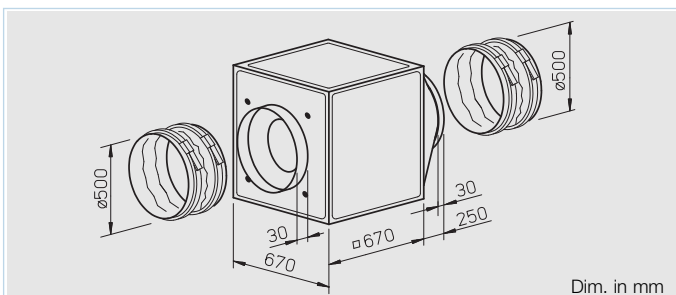

Special features of type GB.. T120

- Designed for moving dirty, humid and hot air volumes up to max. 120° C.
- Motor located outside of air flow.
- Temperature insulated partition panel between motor and impeller, lined with 20 mm thick, flame-retardant mineral wool.
- Easily accessible motor and impeller unit, removable without disassembling the system components.
- Inspection cover with handle, simply remove for cleaning and maintenance.
- Condensate collector with condensate spigot included in delivery. Drill hole for rain drainage (accessories) for outdoor installation is prepared.

Assembly of types GB.. T120

Installation must be carried out with condensation discharge showing downward. Flexible assembly by three possible centrifugal discharge directions via the discharge adapter. Outdoor installation is possible using outdoor cover hood and external weather louvers (accessories).

Feature

Assembly of types GB..

Arbitrary installation position and flexible assembly by five possible discharge directions via the discharge adapter. For wall mounting the wall bracket (accessories) has to be used. Outdoor installation is possible using outdoor cover hood and external weather louvers (accessories).

Specification of both types

Casing

Self-supporting frame construction from aluminium hollow profiles. Double-walled side panels from galvanised sheet steel, lined with 20 mm thick temperature insulating and flame-retardant mineral wool. Intake cone for ideal inflow as well as spigot and flexible sleeve (for the respective max. permissible air flow temperature) for duct connection. With discharge adapter (from square to circular) on the pressure side for low-loss discharge and flexible sleeve to reduce vibration transmission. Simple positioning by standard crane hooks.

Impeller

Smooth running backward curved aluminium centrifugal impeller highly efficient and direct driven. Energy efficient with a low noise development. Dynamically balanced together with the motor to DIN ISO 1940 Pt.1 – class 6.3.

Motor

Maintenance-free external rotor motor or IEC-standard motor protected to IP 44 or 54. With ball bearings and radio suppressed as standard.

Electrical connection

Standard terminal box (IP 54) fitted on the motor; with GB.. T120 fitted on the motor support plate.

Type	Ref. No.	Air flow volume (FID) V m³/h	R.P.M. min⁻¹	Sound press. level case breakout dB(A) at 4 m	Motor power (nominal) kW	Current		Wiring diagram Nr.	Maximum air flow temperature full load controlled		Nominal weight (net) kg	5 step transformer controller with motor protect. unit		Full motor protection unit using the thermal contacts			
						full load A	speed controlled A		+°C	+°C		Type	Ref. No.	Type	Ref. No.	Type	Ref. No.
1 Phase motor, 230 V / 1 ph. / 50 Hz, capacitor motor, protection to IP 54																	
GBW 500/6	5519	5760	880	35	0.52	2.30	2.60	864	45	45	47	MWS 3	1948	TSW 3.0	1496	MW ¹⁾	1579
GBW 500/4	5517	8400	1350	45	1.38	6.40	8.20	865	65	55	61	MWS 10	1946	-	-	-	-
2 speed motor, 3 Phase motor, 400 V / 3 ph. / 50 Hz, Y/Δ-wiring, protection to IP 54																	
GBD 500/4/4	5518	8000/8850	1075/1340	45	0.97/1.45	1.60/2.80	2.90	867	50	50	57	RDS 7	1578	TSD 5.5	1503	M4 ²⁾	1571
1 Phase motor, 230 V / 1 ph. / 50 Hz, capacitor motor, protection to IP 54																	
GBW 500/4 T120	5776	8345	1340	45	1.40	6.1	7.0	301	120	100	75	MWS 10	1946	-	-	MW ¹⁾	1579
2 speed motor, 3 Phase motor, 400 V / 3 ph. / 50 Hz, Y/Δ-wiring, protection to IP 54																	
GBD 500/4/4 T120	5777	7320/8350	1070/1365	45	1.07/1.50	1.80/3.00	3.0	947	120	110	75	RDS 4	1316	TSD 3.0	1502	M4 ²⁾	1571

¹⁾ incl. operation switch

²⁾ incl. operation and 2 speed switch

GBW 500/6

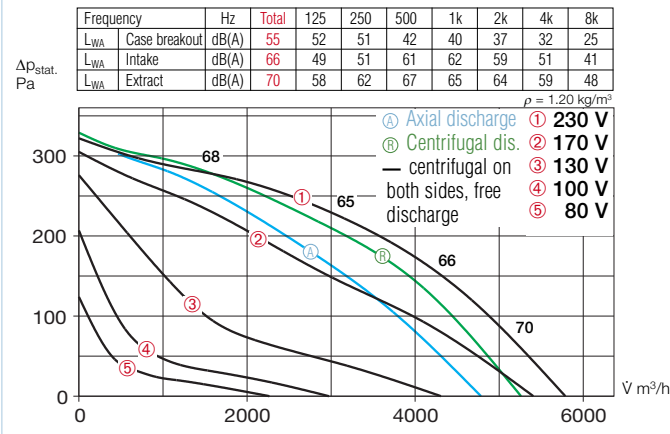

GBW 500/4

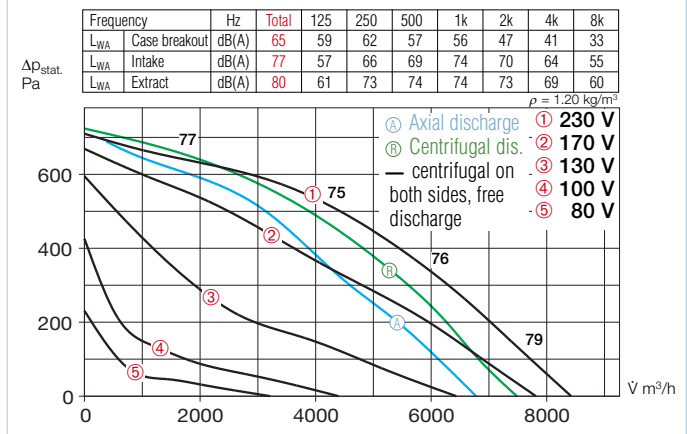

GBD 500/4/4

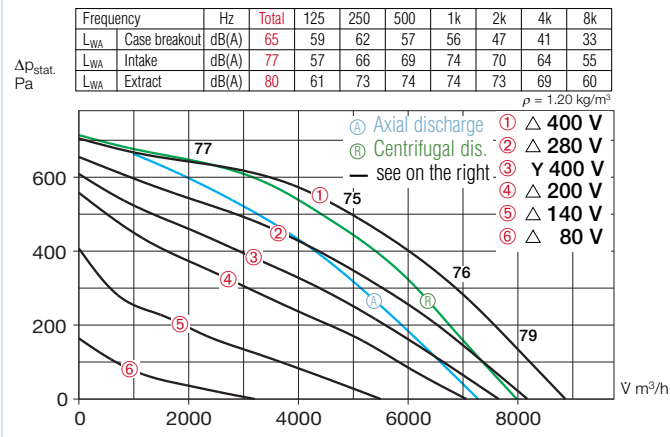

GBW 500/4 T120

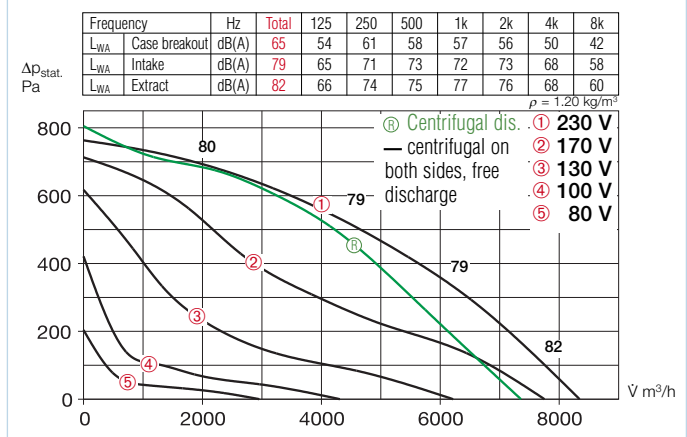

GBD 500/4/4 T120

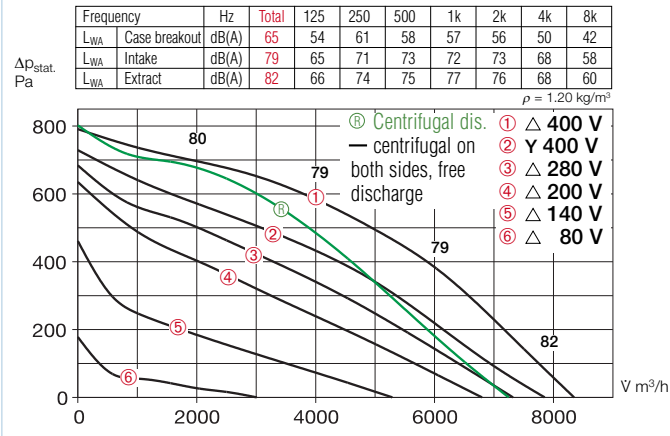

Information	Pages
Design of systems, acoustic	12 on
General techn. information, speed control	17 on
Accessory-Details	Pages
Speed controller and full motor protection unit	397 on

Motor protection

Motors have thermal contacts wired to the terminal block and must be connected to a motor protection unit.

Speed control

All types are speed controllable by voltage reduction using a transformer controller. The 3-phase models can also be 2 speed controlled by star/delta switch (accessories DS 2 or full motor protection unit M 4). The duties at different speeds are given in the performance curve.

Sound levels

Total sound power levels and the spectrum figures in dB(A) are given for:
 - sound level case breakout
 - sound level intake
 - sound level extract
 in the tables above the performance curve. Beside, the sound power level (on intake) is stated over the rated characteristic curve. In the table below you can also find the
 - case breakout level at 4 m (freefield conditions).

Accessories of both types

- Anti vibration mounts** for installation indoors. Set of 4.
SDD-U Ref. No. 5627
- Wall bracket** for wall mounting.
GB-WK 500 Ref. No. 5626
- External weather louvers** to over exhaust opening.
GB-WSG 500 Ref. No. 5639
- Outdoor cover hood** for outdoor installation.
GB-WSD 500 Ref. No. 5748
- On/Off and 2-speed switch** for 3-phase star/delta motors.
DS 2³⁾ Ref. No. 1351

Specific accessories

- for types GB..**
Condensate collector with condensate spigot for pipe connection.
GB-KW 500 Ref. No. 5644
 (Condensate collector with condensate spigot included in delivery with GB.. T120).
- for types GB.. T120**
Rain drainage for outdoor installation (drill holes for rain drainage is already prepared).
GB-RA Ref. No. 9418

³⁾ full motor protection unit recommended: MD Ref. No. 5849



CASED AXIAL ACCESSORIES

SILENCER

PERFORMANCES

The performances are derived from tests to BS848. Measurements of fan noise are made with and without the silencer in position. The difference between recorded levels is the dynamic (with airflow) attenuation or insertion loss of the silencer. Type B silencers may be directly coupled to both inlet and outlet flanges of the fan. When type C silencers are directly coupled to the fan flanges they are most effective on the outlet. A spacer duct of 1D length between the fan inlet flange and a type C silencer is necessary to ensure maximum performance.

Note: C type silencers mounted close to a fan may effect the aerodynamic performance.

CONSTRUCTION

Casings are of rolled, pre-galvanised sheet steel with spun end rings incorporating tapped inserts for fixing. Suitable fixing screws are provided with all steel silencers.

The absorbent material is acoustic grade mineral fibre with an erosion resistant facing. It is protected and contained by a pre-galvanised perforated steel sheet formed to match the fan diameter.

Cylindrical silencers shall be suitable for air pressures up to a maximum of 1000 Pa. For duct pressures in excess of 1000 Pa please enquire.

A Melinex Lining (variant code M) can be supplied for critically clean applications such as hospitals to ensure no fibre migration. The lining may also be used in moisture or grease laden conditions, such as kitchen extract systems where the material is used to stop the ingress of grease etc. into the acoustic media.

The use of the lining also allows the silencers to be low pressure steam cleaned. Some reduction of attenuation due to the lining will be experienced.

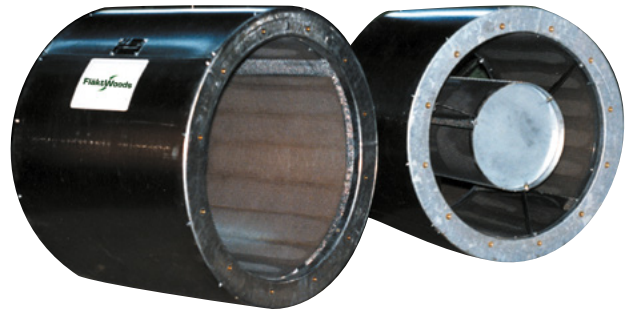

SIZE RANGE

Type B silencer bore diameters range from 280 mm to 1000 mm metric range in lengths equal to or twice the bore diameter (1D or 2D) Pressure loss for type B silencers is the same as a plain duct.

Type C silencers have a centrally mounted absorbent pod in the airway for increased attenuation. The pressure loss due to the pod is provided in Fan Selector when selecting the C type silencer as an accessory.

The diameter range is 315 mm to 1000 mm metric range.

FINISHES

Standard finish is galvanised zinc coating to BS2989 Z2. Other finishes including epoxy paint are available to special order.

TEMPERATURE RANGE

Standard silencers are suitable for temperatures from -40°C to 200°C. When moisture resistant lining is used the continuous air handling temperature is limited to 80°C. Special treatments enable silencers to operate at temperatures up to 600°C. For smoke applications, please enquire.

MOUNTING

Galvanised steel mounting feet and matching flanges corresponding to those supplied for Aerofoil fans are available.

CASED AXIAL ACCESSORIES

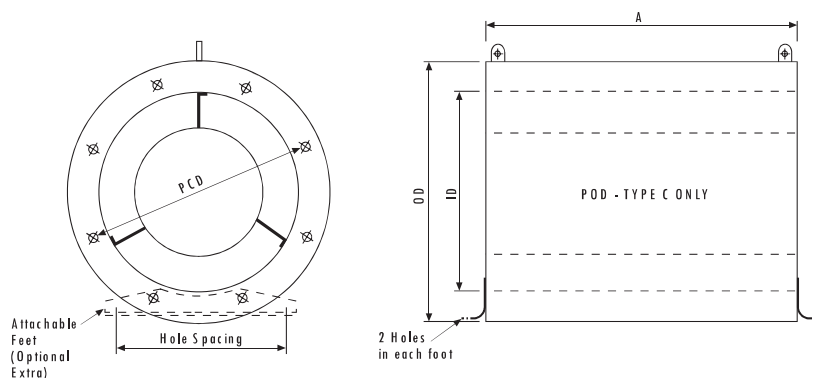

B TYPE SILENCER

Bore Dia. mm (A)	Product Number (B1D)	OD	No of holes	PCD	Thread	Mounting Foot holes		A Length		Weight (kg)	
						Dia	Spacing	1D	2D	1D	2D
315	SB211401	415	8	355	M8	10	265	315	630	10	17
355	SB221401	455	8	395	M8	10	305	355	710	12	20
400	SB241401	500	8	450	M10	10	350	400	800	15	25
450	SB251401	600	8	500	M10	10	400	450	900	20	33
500	SB271401	650	12	560	M10	10	450	500	1000	25	41
560	SB281401	710	12	620	M10	10	510	560	1120	30	50
630	SB301401	780	12	690	M10	12	580	630	1260	35	61
710	SB311401	860	16	770	M10	10	660	710	1420	44	76
800	SB331401	1000	16	860	M10	12	750	800	1600	55	96
900	SB341401	1100	16	970	M12	12	850	900	1800	70	129
1000	SB351401	1200	16	1070	M12	12	950	1000	2000	82	157

C TYPE SILENCER (PODDED)

Bore Dia. mm (A)	Product Number (C1D)	OD	No of holes	PCD	Thread	Mounting Foot holes		A Length		Weight (kg)	
						Dia	Spacing	1D	2D	1D	2D
315	SC211401	415	8	355	M8	10	265	315	630	13	19
355	SC221401	455	8	395	M8	10	305	355	710	15	24
400	SC241401	500	8	450	M10	10	350	400	800	18	30
450	SC251401	600	8	500	M10	10	400	450	900	24	39
500	SC271401	650	12	560	M10	10	450	500	1000	29	48
560	SC281401	710	12	620	M10	10	510	560	1120	35	58
630	SC301401	780	12	690	M10	12	580	630	1260	42	72
710	SC311401	860	16	770	M10	10	660	710	1420	53	90
800	SC331401	1000	16	860	M10	12	750	800	1600	66	116
900	SC341401	1100	16	970	M12	12	850	900	1800	84	150
1000	SC351401	1200	16	1070	M12	12	950	1000	2000	100	182



CASED AXIAL ACCESSORIES

SILENCER ACOUSTIC PERFORMANCE

TYPE B DYNAMIC ATTENUATION

BORE DIA. MM (D)	LENGTH	OCTAVE-BAND MID FREQUENCIES HZ							
		63	125	250	500	1K	2K	4K	8K
315	1D	1	2	4	9	11	10	9	7
	2D	1	2	5	11	16	12	11	10
355	1D	1	2	4	10	12	10	9	7
	2D	2	3	6	13	17	14	11	11
400	1D	2	3	5	10	13	11	9	8
	2D	3	4	7	14	18	15	11	12
450	1D	2	3	6	12	13	11	10	6
	2D	3	4	8	17	18	15	11	11
500	1D	2	3	6	13	14	10	10	5
	2D	3	4	8	19	18	14	11	10
550	1D	2	4	7	14	14	9	10	7
	2D	3	5	9	19	18	14	12	11
630	1D	2	5	7	15	13	8	9	8
	2D	4	6	9	19	19	14	13	12
710	1D	2	5	7	15	13	9	9	8
	2D	4	6	9	19	17	13	12	11
800	1D	2	5	8	16	12	9	9	8
	2D	4	6	10	19	15	12	11	10
900	1D	2	5	10	17	13	11	10	8
	2D	4	6	12	19	15	12	11	10
1000	1D	4	5	11	16	11	10	8	9
	2D	4	6	13	19	14	12	11	11

TYPE C DYNAMIC ATTENUATION

BORE DIA. MM (D)	LENGTH	OCTAVE-BAND MID FREQUENCIES HZ							
		63	125	250	500	1K	2K	4K	8K
315	1D	2	5	5	9	18	20	18	15
	2D	2	6	6	12	20	25	20	17
355	1D	2	5	6	9	18	22	19	16
	2D	2	6	7	13	25	27	21	17
400	1D	2	6	6	10	19	24	20	17
	2D	3	7	8	14	29	29	23	18
450	1D	2	4	7	13	20	23	22	17
	2D	2	5	9	16	29	29	21	20
500	1D	2	3	8	16	21	22	21	17
	2D	2	4	10	20	29	30	20	26
550	1D	3	5	8	16	20	18	19	15
	2D	4	5	10	20	29	28	21	23
630	1D	3	5	8	15	19	16	14	12
	2D	5	6	10	19	29	25	21	20
710	1D	3	5	8	15	19	15	14	12
	2D	5	6	10	20	26	23	18	17
800	1D	4	5	8	16	19	15	14	13
	2D	5	7	11	22	23	21	16	14
900	1D	4	5	9	17	19	15	14	13
	2D	5	7	12	24	23	21	16	15
1000	1D	5	5	11	18	19	15	14	13
	2D	5	7	13	26	24	20	16	16

All performances are derived from tests to BS848.

The above silencers give the following approximate dBA reductions: -

B Type 1 diameter length - 7 to -10 dBA

C Type 1 diameter length - 12 to -15 dBA

For full acoustic details and resistance to airflow for type C please refer to fan selector.



Anti Vibration Mounts (AV's)

Introduction

Anti-vibration mounting kits are available in both rubber and spring type, the correct selection and type employed will depend on the accurate calculation of the weight of the assembly to be supported.

Installation

AV mounts should not be fitted to a fan/silencer assembly unless there are flexible connectors fitted between the assembly and associated duct work.

AV mounts should be installed with the matched mounting feet and positioned such that they carry an equal proportion of the assembly weight. This is particularly important where fans and silencers are installed on suspension rods.

Figure 1. NAV 1 to NAV 5 (Resilient Rubber)

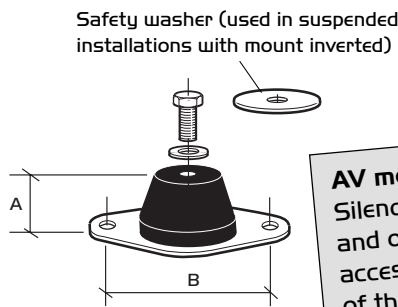

Figure 2. NAV 6 (Resilient Rubber)

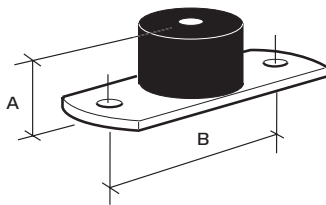
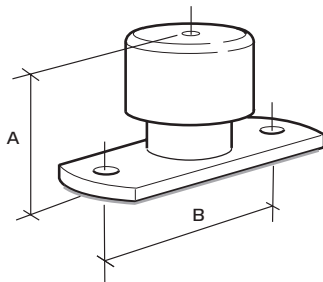

Figure 3. NAV 49 to NAV 58 (Spring)



AV mounts are maintenance free but a periodical inspection is recommended to check security of fixings and condition of rubbers and springs.

Resilient Mounting Details

Figure 4.

NAV 1 to NAV 5 shown in floor (Figure 4) and suspended configurations (Figure 5).

Fans using size NAV 6 upwards require supporting steelwork to be designed (by others) for suspended applications.

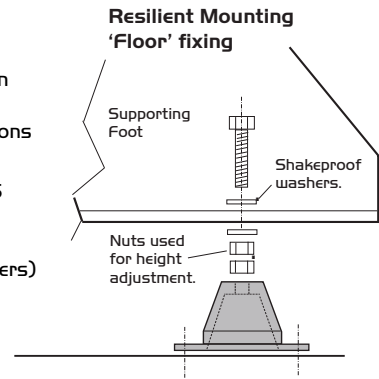
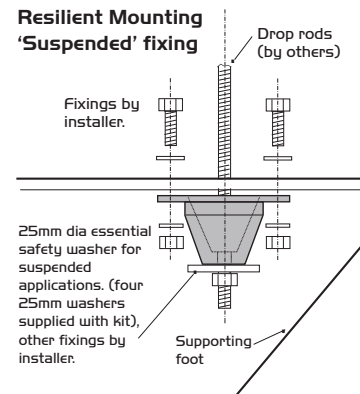

Figure 5.



AV mounts isolate the fan only. Silencers/backdraught dampers and other "significant mass" accessories should form part of the fixed ductwork after the flexible connection.

Dimensions (mm) and Weights

Rubber Type

Code	A	B	Max. kg per kit
NAV1	30	50	20
NAV2	40	75	80
NAV3	40	75	180
NAV4	40	75	260
NAV5	40	75	130
NAV6	50	100	320

Spring Type

NAV49	77	76	400
NAV50	77	76	480
NAV51	77	76	520
NAV52	87	127	600
NAV53	87	127	700
NAV54	87	127	800
NAV55	87	127	950
NAV56	87	127	1110
NAV57	87	127	1270
NAV58	87	127	1430



Nuaire Limited Western Industrial Estate Caerphilly United Kingdom CF83 INA



www.nuaire.co.uk